

FUTURE

OF

WHAT'S AHEAD FOR THE RESTAURANT INDUSTRY

2022 



TREND REPORT

RESTAURANTS

CONTENTS



03	Introduction
06	Ongoing labor shortage
09	Automation is not a bad word
13	Omnichannel strategy
17	On-demand delivery
20	Self-serve ordering
24	More ways to pay
27	Diverse revenue streams
31	Building community
36	Methodological notes

INTRODUCTION

The restaurant industry is going through a period of change, accelerated by the pandemic and access to innovative technology. To understand where the future of the restaurant industry is headed, we worked with Wakefield Research to survey [500 restaurateurs](#) and [1,000 consumers](#) for our second annual Future of Restaurants report. We also gathered insights from successful Square sellers and industry insiders. Restaurant owners share their experiences over the past year and give us a glimpse into what the industry may look like over the next year.

While 58% of restaurateurs say they are concerned about the survival of their restaurant, that's down from 92% the previous year. Some restaurants are moving out of survival mode and into thinking about long-term strategies to future-proof their businesses, embracing data and technology to help them get through ongoing challenges such as the labor shortage and supply chain issues.

THREE PREDICTIONS FOR THE FUTURE OF RESTAURANTS

By Lior Koren
Product Lead, Square for Restaurants

Based on my experience at Square, I see three key areas of opportunity in the industry:

01

Diversification

Restaurants will continue to expand beyond their physical footprint (delivery, pickup, curbside) and into different types of revenue streams (retail, subscriptions, etc.) to meet customers where they are.

02

Personalization

Restaurants will offer more personalized experiences to their diners by leveraging data and technology to create both in-person and virtual hospitality. The relationship will expand into a digital experience, where diners can interact with restaurants at any time from anywhere.

03

Virtual brands

Virtual brands will become more common as restaurants expand to ghost kitchens to grow their footprint and test new concepts, or expand to virtual brands in their existing kitchen to bring in revenue when demand is low for their main on-premise brand.

Ongoing labor shortage



INSIGHT

→ The labor shortage may be a new normal for restaurants, and they'll have to adapt.

The pandemic was an inflection point for businesses across industries, but especially for restaurants. As employees reassess opportunities and benefits, restaurants may have to shift how they operate. Key strategies to address this challenge could include making the work environment more enticing for employees and making more strategic staffing decisions.

//

Across the industry, staffing continues to be the No. 1 challenge restaurants face. As states continue to increase minimum wages and demand for restaurant staff continues to be robust, restaurants may need to compensate front-of-house and back-of-house staff more and provide benefits historically not ubiquitous in order to attract and retain employees. This means that labor costs may go up, and restaurants may need to find ways to operate with more efficient labor. This is where we believe restaurants can lean on tech — to help them better utilize their existing staff, manage their labor cost, and maintain delightful customer experiences.”

Bryan Solar
GM, Square for Restaurants

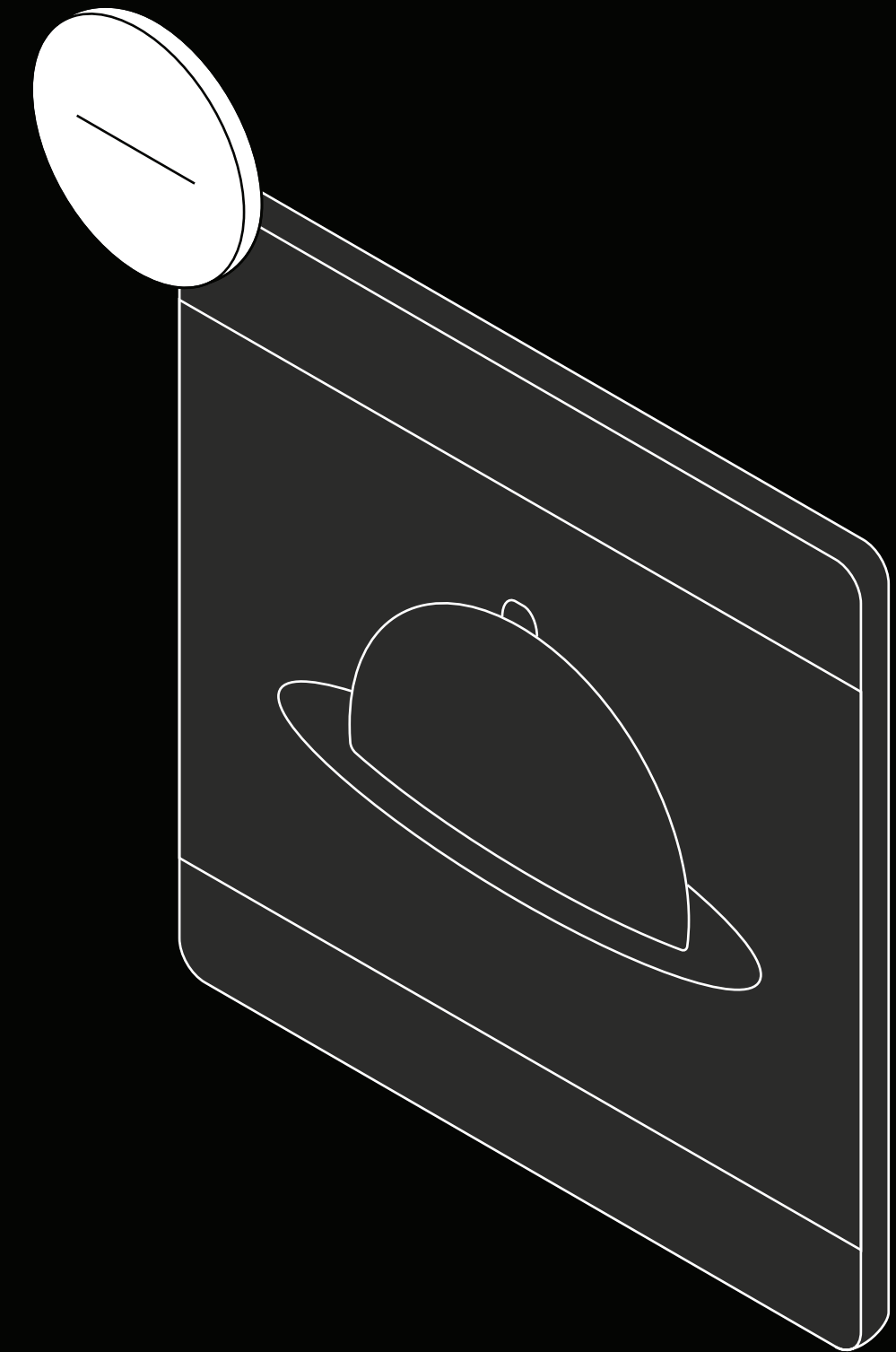

73% of restaurants say they are experiencing a labor shortage.

Restaurants say that an average of **21%** of positions are unfilled.

DID YOU KNOW?

With [Square for Restaurants](#), you can see [live sales and shift reports](#) to inform your staffing strategy.



Tips

- Review the benefits you offer employees. Are they competitive enough to successfully attract and retain employees? [Square Payroll](#) partners with providers to help employers save time while managing worker's compensation, health insurance, and retirement and 401(k) benefits.
- Leverage data to understand the best way to utilize your team so that you don't overstaff during slow shifts.
- Consider ways to help staff be more efficient with their time. For example, incorporating [QR code ordering](#), tableside ordering, and tableside payments can cut down on time servers spend going back and forth from the customer to the POS. An integrated [Kitchen Display System](#) can also help with back-of-house efficiency, making the kitchen staff feel less overwhelmed with incoming tickets.



//

We started diving into the Square Dashboard, the history, the performance, the numbers, the percentages, and tracking our performance, making difficult decisions, such as should we have weekend brunch or shouldn't we? Does it make financial sense to have it or not?"

Leyla Khanahmad
Owner, Black & Caspian, Chicago, IL



INSIGHT

→ At this critical juncture, some restaurants are realizing that automation is not a bad word.

Section — 02

Automation is not a bad word

Amid the labor shortage, technology can free up staff in both the front and back of the house, enabling them to focus on more high-impact work and saving restaurants labor costs. This is helpful, as restaurants launch on new channels and as online ordering, delivery, and multiple business lines become more normal.

62% of restaurants say that automation would fill critical gaps in managing orders placed online, at the restaurant, and via delivery apps.

91% of restaurants say that automation with inventory/item availability would help fill critical business gaps.

36% of restaurants upgraded business technology this past year.

30% of restaurants say that they currently use a single integrated application to manage back-of-house operations.

Q: Which of the following best describes the technology you use to manage your back of house operations, such as managing orders and processing payments?

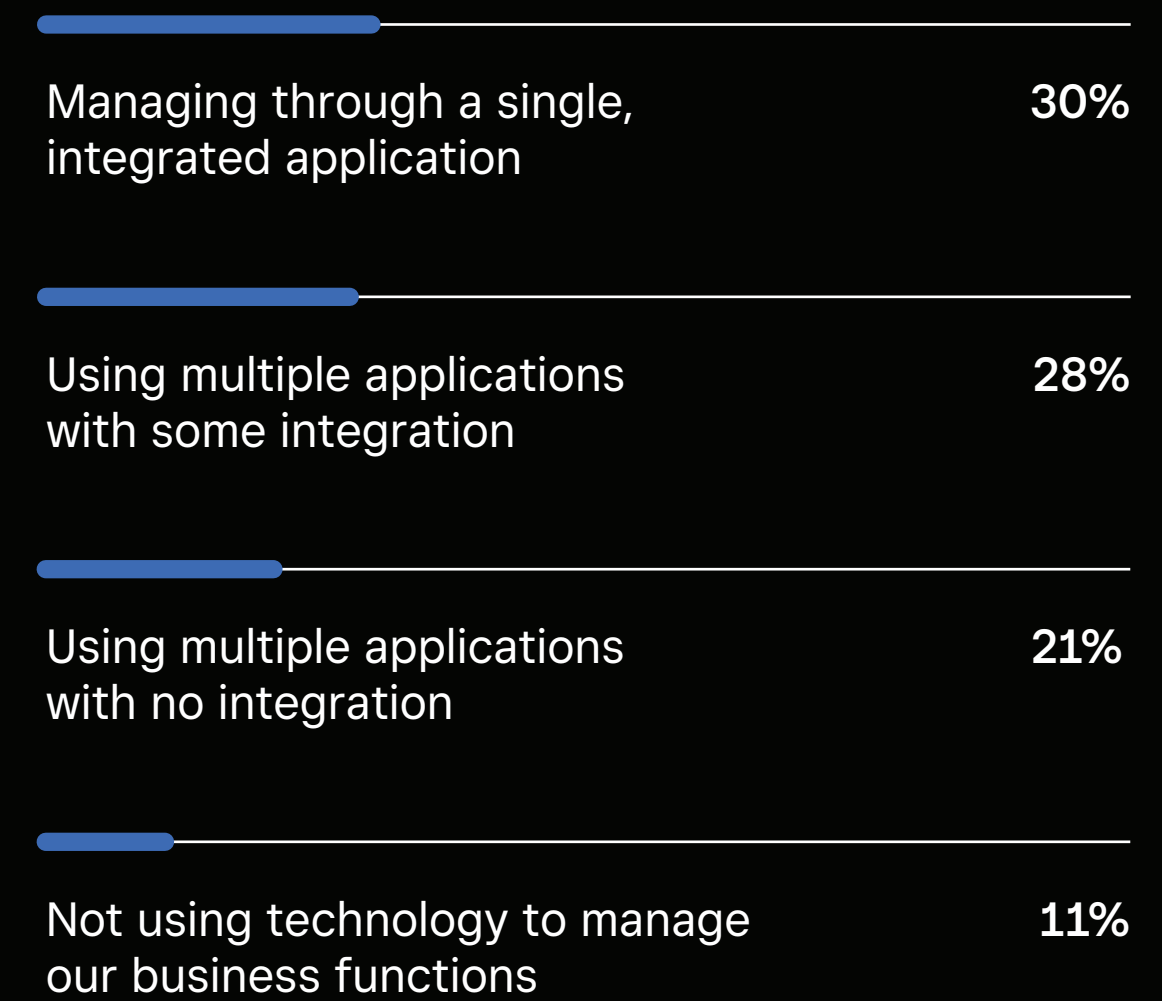

90% of restaurants agree that increased automation for back-of-house operations would allow staff to focus on more important tasks.

Q: Where would automation help to fill critical gaps, if at all, when you are not at full staffing capacity?

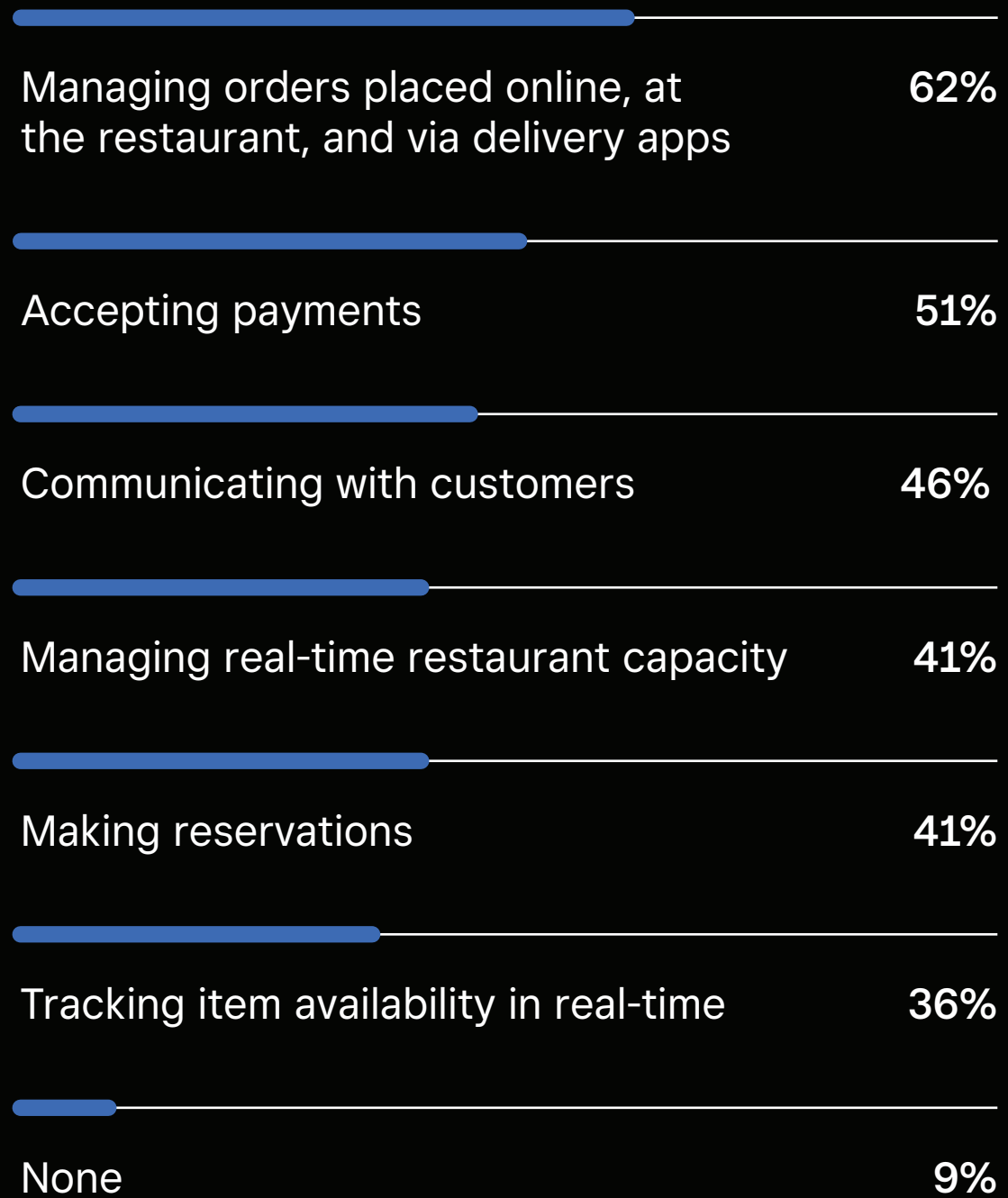

DID YOU KNOW?

The [Square App Marketplace](#) allows you to sync a variety of apps with Square and add all kinds of new capabilities, such as accepting delivery orders via social media or managing restaurant inventory.

//
Our labor cost percentage for an entire beer garden is **150% less** than it was when I owned a 300-square-foot [frozen yogurt] shop, and that's entirely because of QR code ordering."

Liz Fielder
Co-owner, The Junction, Mill Valley, CA

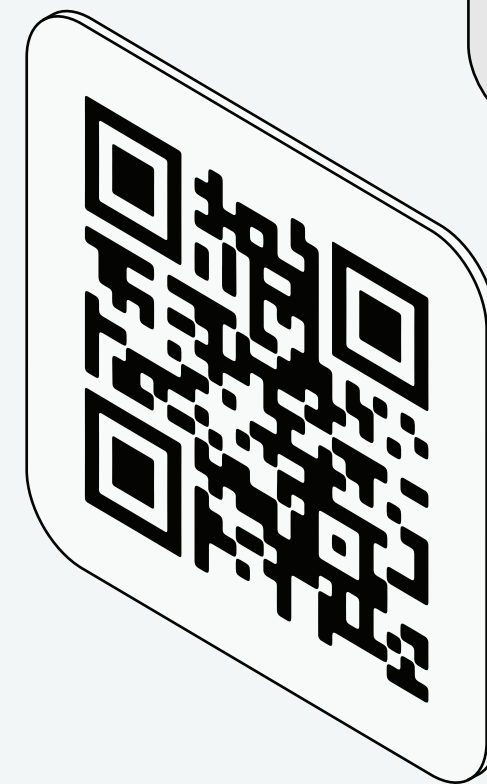
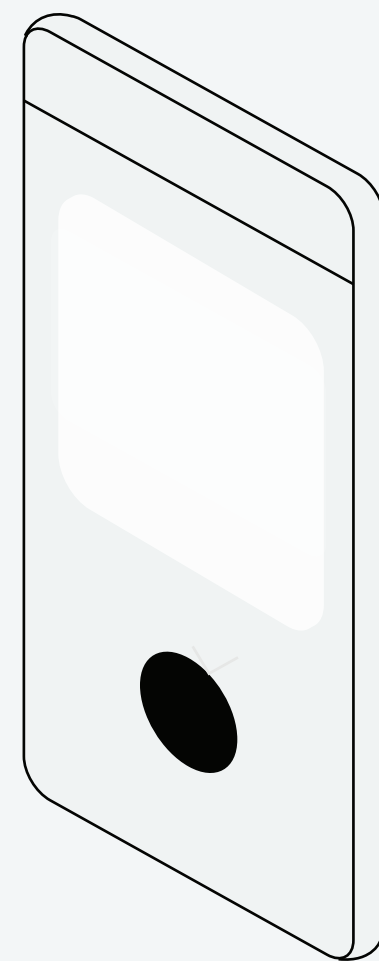

Tips

- Consider centralizing your tech with one vendor to avoid troubleshooting with many different vendors or having disparate data because the tools don't integrate with each other.
- Automate payroll tasks to save your managers from time-intensive spreadsheets. For example, the [Square for Restaurants](#) tip pooling feature calculates tips and automatically takes care of taxes.

Omnichannel strategy



INSIGHT

→ Even as in-person dining ramps back up, restaurants may want to have an omnichannel strategy that implements online ordering and delivery.

“We see the time of the dine-in only or takeout only as largely done forever,” says Bryan Solar, GM of Square for Restaurants. “In the future, we expect restaurants’ physical footprints to evolve as they see an increase in the percentage of their revenue that comes from off-premise sales. Kitchen sizes could potentially take up more of the overall space and online ordering would become critical to a restaurant’s bottom line.”

Restaurants that offer online ordering say that an average of **34%** of their revenue currently comes from those channels.

13%

of customers would avoid a restaurant with no online ordering.

54%

of restaurants added or expanded options to take online orders over the past year.

69%

of restaurants say that they plan to offer online ordering even after COVID-19 subsides.





//
I will punch this into the sky: Your digital experience is now just as important as your food experience.”

Wally Sadat
CEO, The Kebab Shop

//
[The pandemic] has validated our omnichannel strategy. It has validated everything. We went into this thinking that we wanted to be wherever our customers are. Of course, that's all of the social channels, and it's search, it's the web, it's mobile — it's giving them as many ways to transact within the venue as frictionlessly as possible.”

Mark Stutzman
CTO of Area15, Atlantic: Rethink

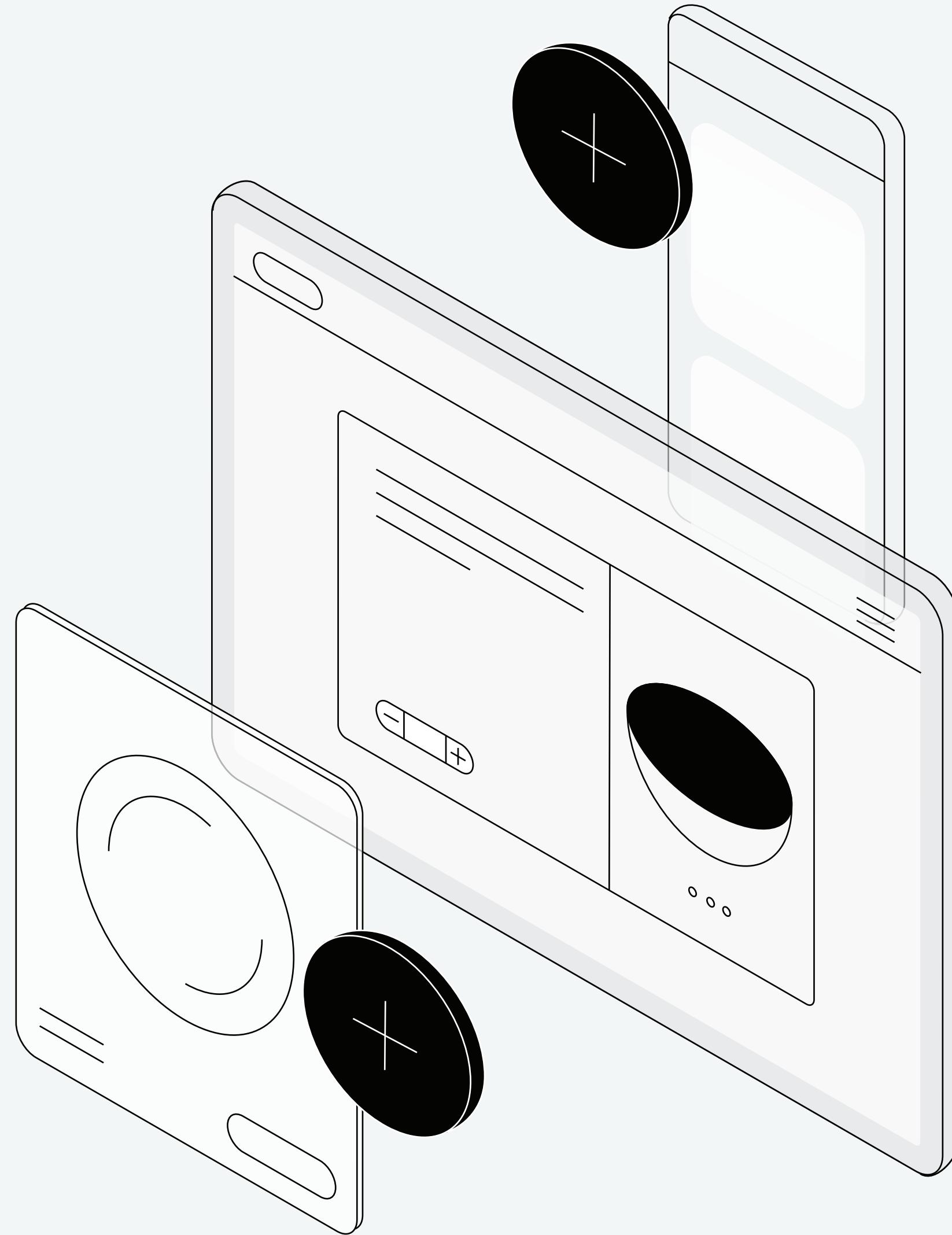

Tips

- Make it easy for customers to discover you. Square has [partnered with Google](#) to simplify linking your profile to your online store. Optimize your website for [search](#), update your [Google My Business](#) profile, and connect your site to Google using [Order With Google](#), which allows customers to order directly from search results.
- Have clear navigation on your website for online ordering, pickup, and delivery.
- Include [high-quality food photos](#) on your online ordering site.
- Include thorough menu descriptions and add common allergens or diet-friendly dishes (think: vegan, gluten-free, nut-free, etc.).

On-demand delivery



→ Many restaurants are moving toward delivery directly from their sites.

More restaurants are looking for viable options to provide direct delivery or to share drivers with other restaurants nearby. Not only do these restaurants save on third-party commission fees, but they get customer data and own the customer relationship end-to-end. This opens up new ways for restaurants to provide hospitality and build brand recognition up until the point of meal drop-off.

49% of restaurants say that they plan to offer first-party delivery, while 62% say that they plan to offer third-party delivery.

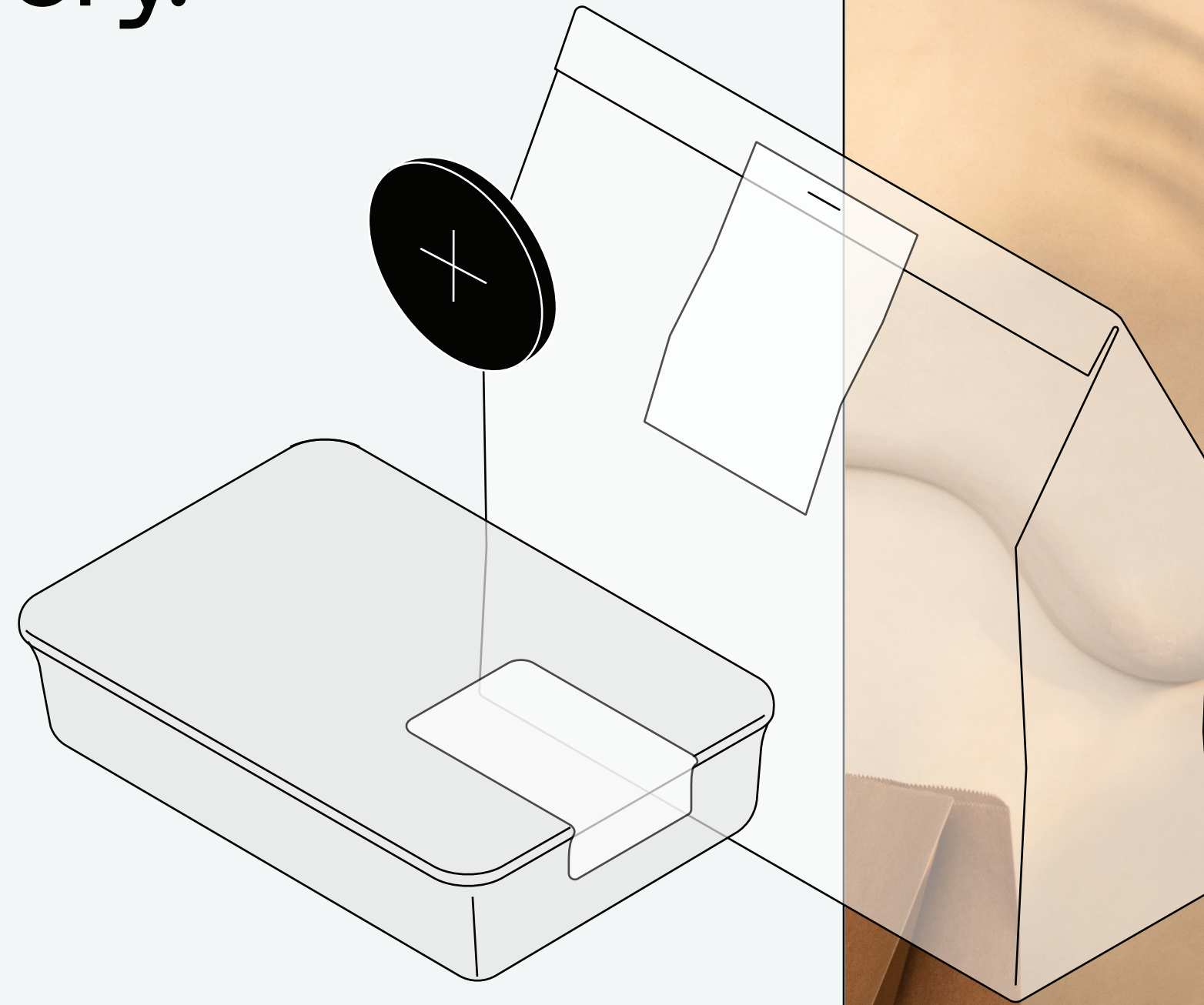

68%

of customers prefer to order delivery through a restaurant's own website or app.

24%

of restaurants say that they plan to offer alcohol delivery.

DID YOU KNOW?

[Square On-Demand Delivery](#) gives you access to professional third-party couriers instead of hiring your own staff. With On-Demand Delivery, you won't have to pay commissions; just a flat fee of \$1.50 per order. You can choose to cover the fee, pass the local delivery costs on to your customers, or cover local delivery for orders over a certain amount (e.g. free delivery for orders over \$50).

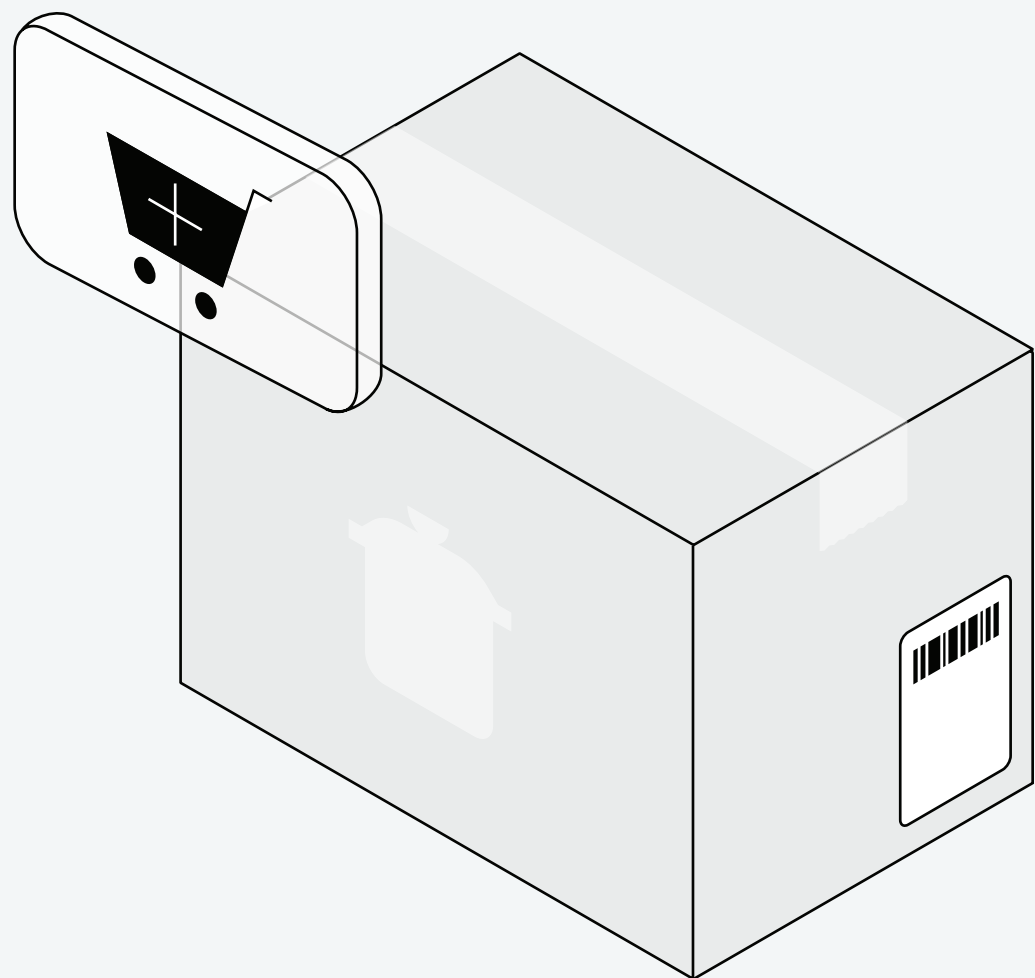

Tips

- With delivery directly from your site, you have access to [valuable customer data](#) that will help you build a repeat customer base. Use this data to maintain sales histories for customers, making it easy for you to build relationships and incentivize them to become repeat customers.
- Let customers know that they can order directly from you, with signage in your restaurant, on your website and social accounts, and in your email communications.



INSIGHT

→ Self-serve ordering is here to stay, and it can benefit restaurants and customers.

Section — 05

Self-serve ordering

Self-serve ordering exploded in popularity during the pandemic as a way to reduce contact between staff and customers. Over the past year both customers and restaurants have experienced its benefits. Customers don't have to wait for staff to take their orders and payments. Restaurants are able to turn tables faster, and [recent Square data](#) show that businesses average a 35% increase in sales within the first 30 days after they implement self-serve ordering with QR codes.

79% of customers say that they'd prefer to order via online kiosks rather than directly through staff — and not just for fast food. 45% of customers prefer it for casual dining and 21% prefer it for fine dining.

11%

of customers would avoid a restaurant with no digital menus.

45%

of restaurants say that they plan to offer QR code menus even after COVID subsides.

78% of customers say that there are benefits to digital menus.

Q: Which of the following, if any, are benefits to using digital menus when dining in a restaurant?

It reduces my contact with surfaces others have touched 38%

I don't need to wait for my server to bring physical menus to the table 37%

It makes it easier to browse the menu 33%

It's better for the environment compared to physical menus 33%

My server doesn't need to explain menu options to me 23%

There are no benefits 23%



We've gotten nothing but amazing feedback on QR code ordering. Regardless of the pandemic, this is a model our customers prefer. It's faster, it's easier, and guests still feel like they're getting a lot of personal interaction."

Liz Fielder
Owner, The Junction

DID YOU KNOW?

Square offers [self-serve ordering](#). Customers scan QR codes to view menus, order, and pay for their meals directly on their phones. If you prefer kiosks, you can easily turn tablets into self-ordering kiosks with the Square App partner [GRUBBRR](#).

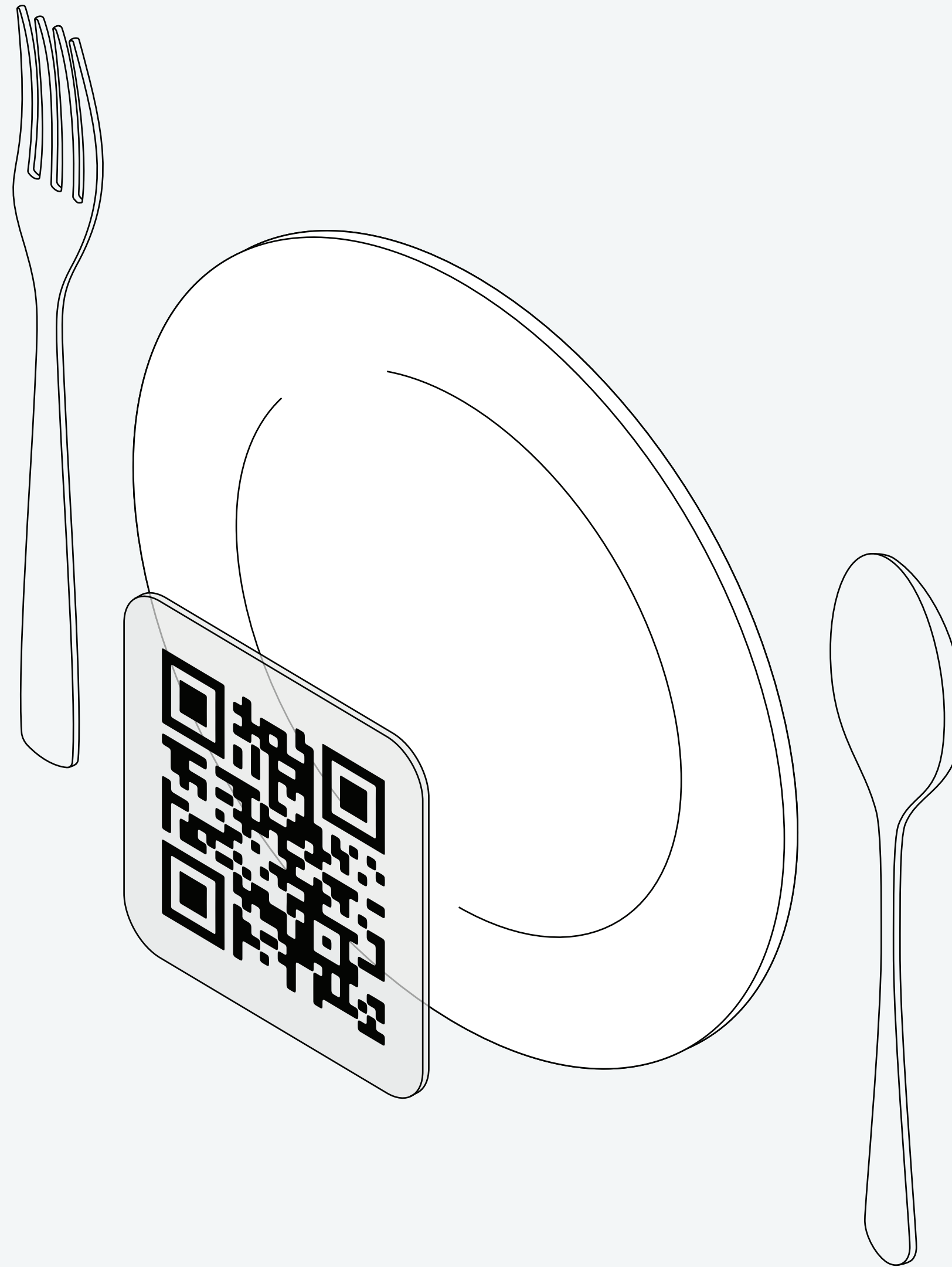

Tips

- Allow customers to self-serve order from QR code menus by placing a scannable QR code on the table. Make sure there's enough contrast with the QR code and the background so that it is scannable even in low light.
- Keep your digital menus updated. You can easily add specials for limited-time offerings to minimize staff time reciting those for the customer.
- Solve for supply-chain shortages with QR code menus. You can easily 86 items when they are out of stock, eliminating extra back and forth between staff and customers.

Digital menus and dynamic pricing

Due to supply shortages and labor shortages, the cost of many goods is going up.

As a result, some restaurants are experimenting with dynamic pricing. Think of it as more menu items that are listed as Market Price. Digital menus help communicate fluctuating prices and lessen the workload of printing new menus constantly. And **77%** of customers say that they would understand if their favorite local restaurants raised prices.



More ways to pay



INSIGHT

→ Customers now expect more efficient payment options, which can help restaurants turn tables, increase revenue, and adapt to the labor shortage.

Many customers, especially younger diners, want options for how they dine and how they pay. Restaurants that provide a variety of options can improve the customer experience, and contactless payments and tableside payment devices can help businesses run more efficiently.

Q: Which of the following payment options do you currently offer?

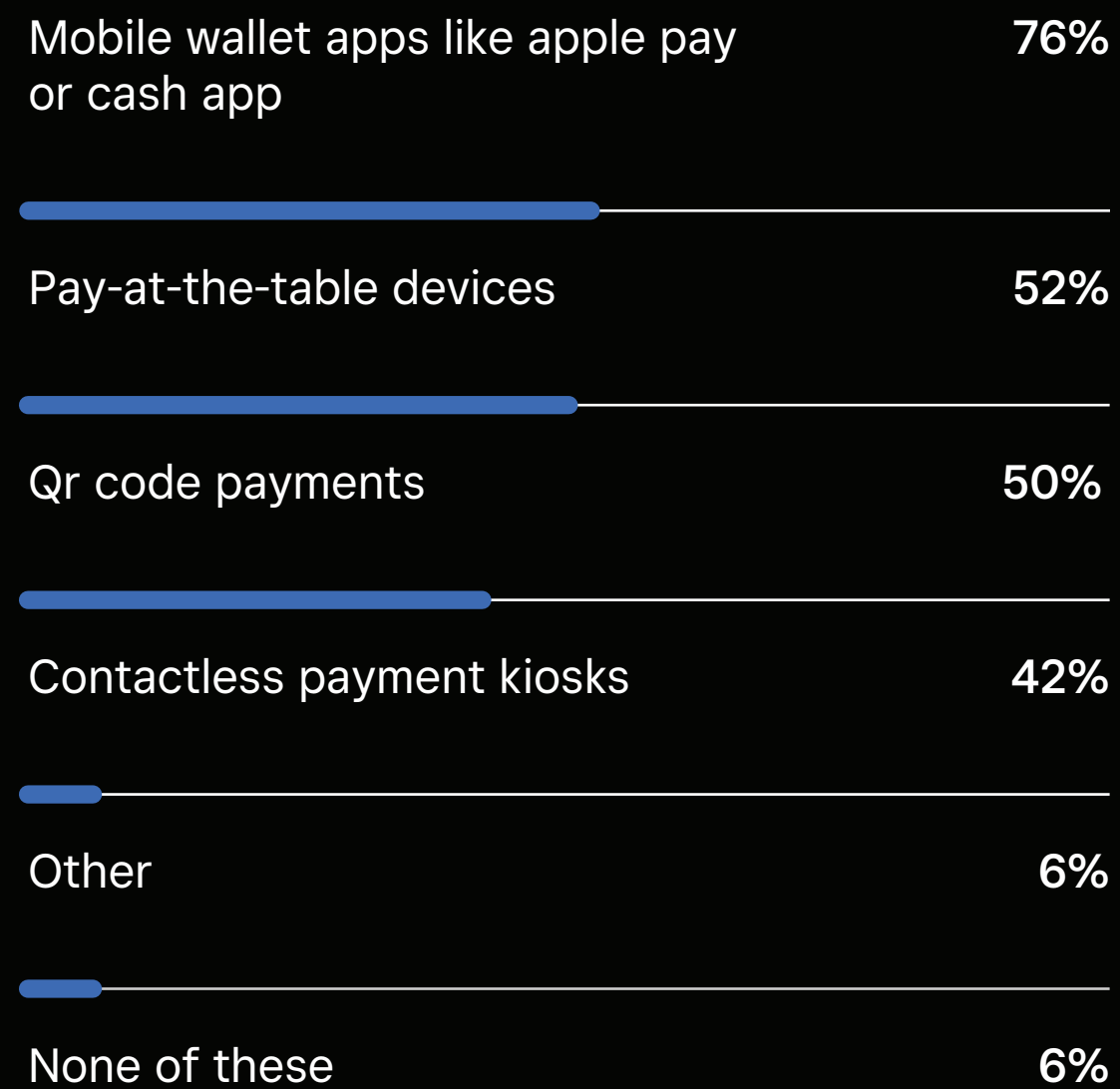

94% of restaurants surveyed say that they currently offer contactless payment options.

Additionally, 52% of restaurants surveyed say that they plan to offer tableside payment options.

23%

of consumers prefer to pay tableside.

43%

of millennial and Gen Z diners prefer contactless payment methods.

14%

of consumers would avoid a restaurant that doesn't have contactless payments.

29% of consumers prefer contactless payments such as mobile wallets, contactless payment kiosks, and QR code payments.

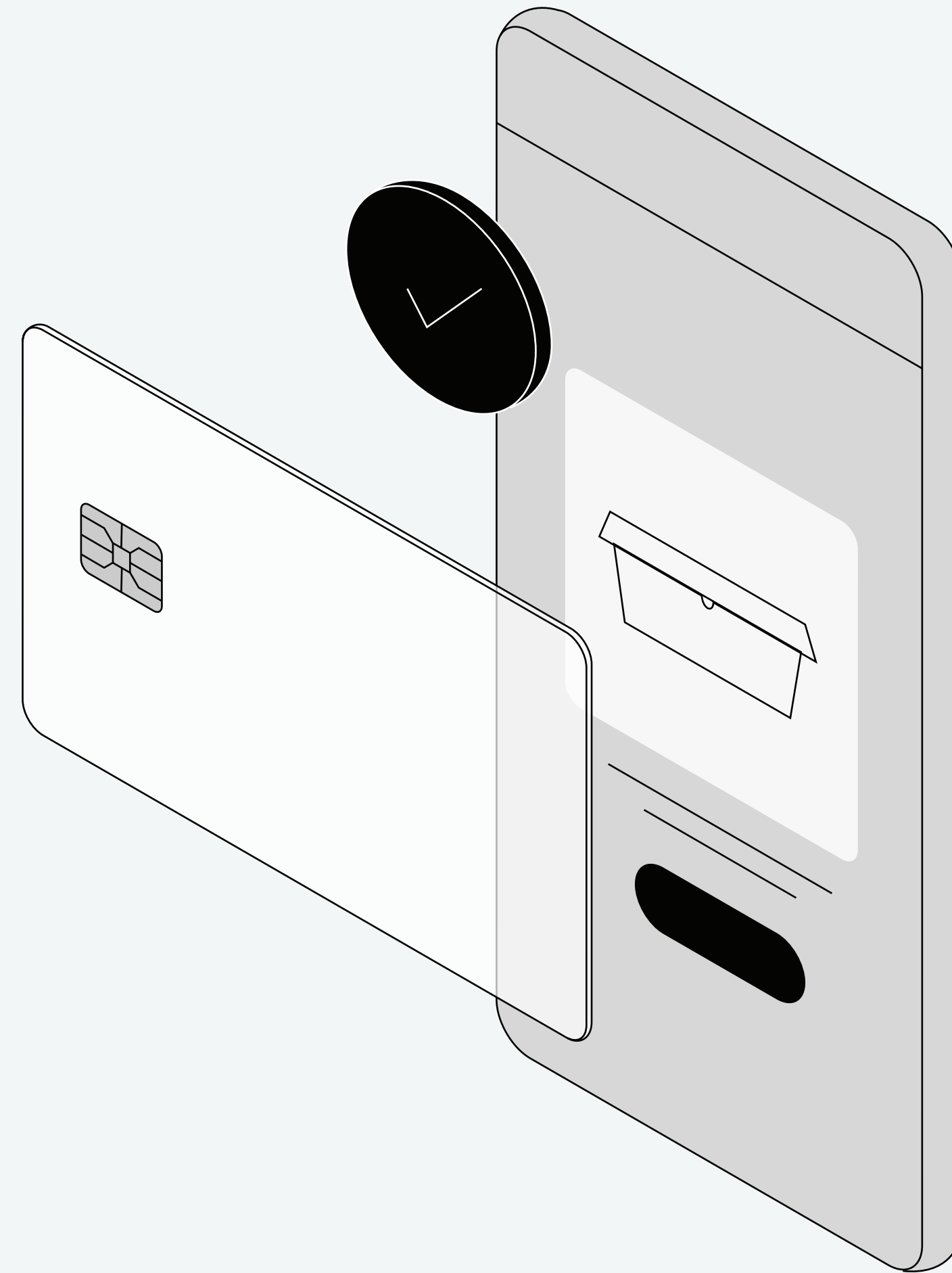

DID YOU KNOW?

With [Square](#) you can offer a variety of payment options. These include standard or contactless credit card payments; tableside device payments; mobile wallet apps such as Cash App and Apple Pay; QR codes; and email or SMS payment links.

Tips

Offer contactless payment options such as [mobile wallet](#), QR code payments, or tap, swipe, and dip payments to cut down on time for customers to complete transactions.

If your business accepts [Cash App Pay](#), customers can use it to track their points and rewards at your business.

Your payment technology should give you real-time reports that will help you manage inventory, track your sales, and decide the best next steps for your business.

[Square Terminal](#) can be used to make tableside ordering and payments quicker and easier.



INSIGHT

→ Many restaurants continue to add new, diverse revenue streams.

Section — 07

Diverse revenue streams

Many restaurants are thinking about ways to add more revenue streams, from selling retail to offering at-home experiences, subscriptions, memberships, and more. What started as a way to get through pandemic shutdowns has now opened up a whole new world.

Restaurants with revenue streams outside of the core business say that an average of **17%** of revenue comes from those offerings.

50%

of restaurants added new products or services as a result of the pandemic.

44%

of customers bought items from a restaurant outside of standard meals.

75% of restaurants say that pandemic-inspired services or products are here to stay, including:

Subscriptions & memberships

44%

Grocery/retail

42%

Meal/cocktail kits

37%

Virtual tastings

27%

Online cooking classes

25%



//

Have a customer in mind when you decide to add or evolve sales channels. Identify who you want to be your customer, but don't forget about the core customer who has helped keep the lights on. If you see an opportunity to offer new, inventive products and services to your customers, go for it! It could be the exact catalyzer your business needs.

But keep this in mind: When you cast a wider net, it does not always mean a larger return. Find places with existing efficiencies, and ask yourself whether you are thoughtfully expanding your concept in a seamless way or

whether you are throwing things at the wall, hoping things stick. A poorly developed Hail Mary in the business world can be costly and often not generate a return on investment, after considering the time, energy, and money required to make it happen."

Ian VanDam

Owner, The Annex/Frisco, St. Louis

//
Where a portrait artist has somebody they're painting a portrait of, we work more like a sketch artist. We're sketching the business from scratch without a picture that we're mimicking."

Ryan Prellwitz
Vines & Rushes Winery, Rapon, WI

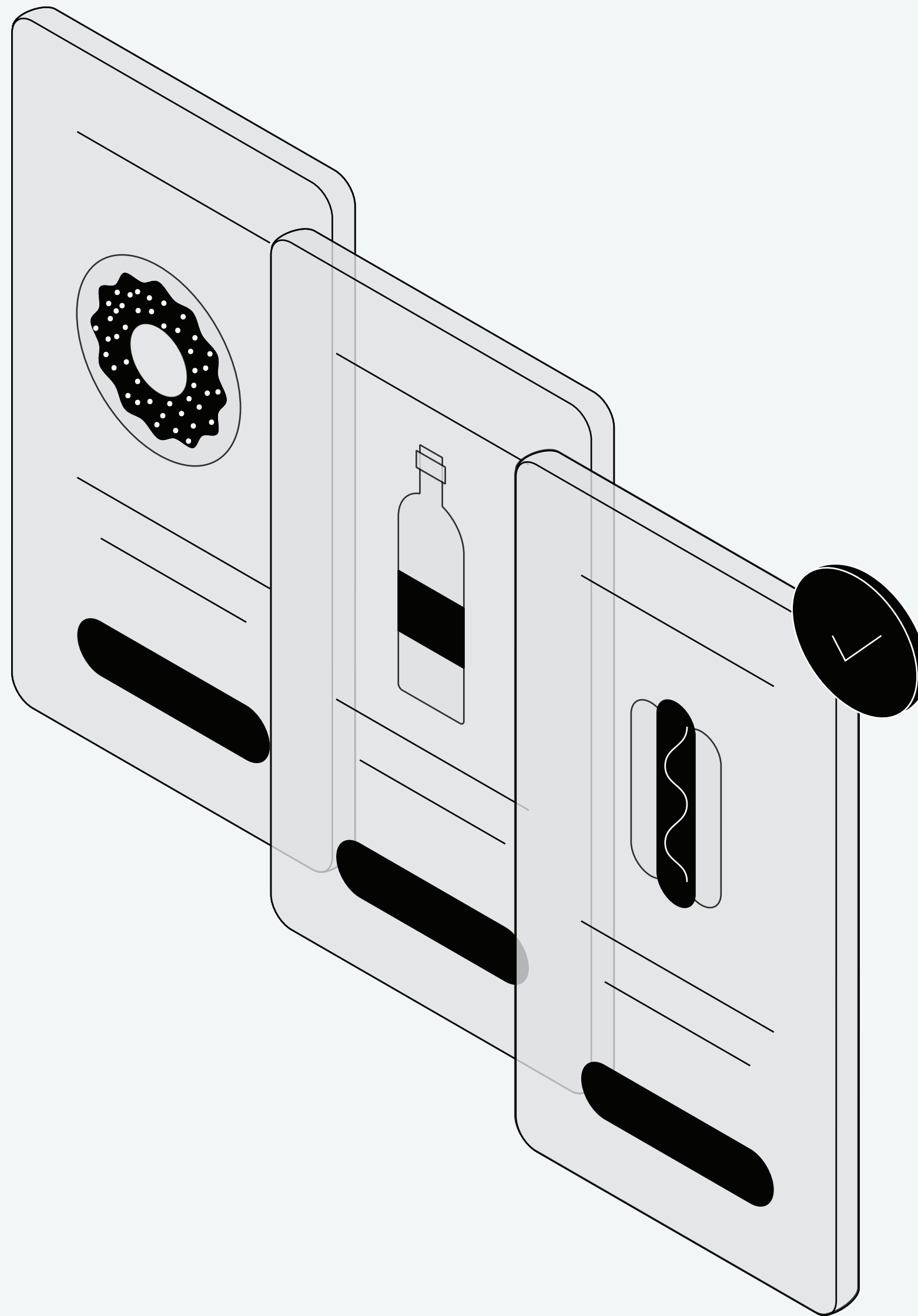

DID YOU KNOW?

The [Square ecosystem of tools](#) allows you to sell many different ways. Easily create subscriptions and memberships, start to sell retail items with built-in shipping integrations, create virtual and in-person events and more.

Tips

- Choose technology platforms that give you flexibility to add new revenue streams outside of traditional restaurant offerings, whether that involves selling retail or adding a VIP monthly membership.
- Promote new offerings across your channels, including email, social media, in-store signage, and on your website.
- Test new offerings as a loyalty perk for regular customers, and solicit their feedback.

Building community



INSIGHT

→ Building a loyal community and customer base can help you stand out from the crowd.

Many customers stepped up to support restaurants over the past two years. It's important to keep these customers engaged and to turn that support into continued revenue, by connecting with them across multiple touchpoints. Luckily, thanks to the data that restaurants now have available, it's much easier to know your customers and build relationships with them.

//

Customers are the lifeblood of restaurants, but often it feels as if restaurants are only able to glean bits and pieces of who their customers are. New tools help restaurants recognize who their regular customers are, which customers churned (and why they churned), and, overall, how customers are experiencing the restaurant. This can unlock a lot of opportunities for restaurants to build a larger loyal customer base, as well as launch new revenue streams that will appeal to their customers."

Bryan Solar
GM, Square for Restaurants

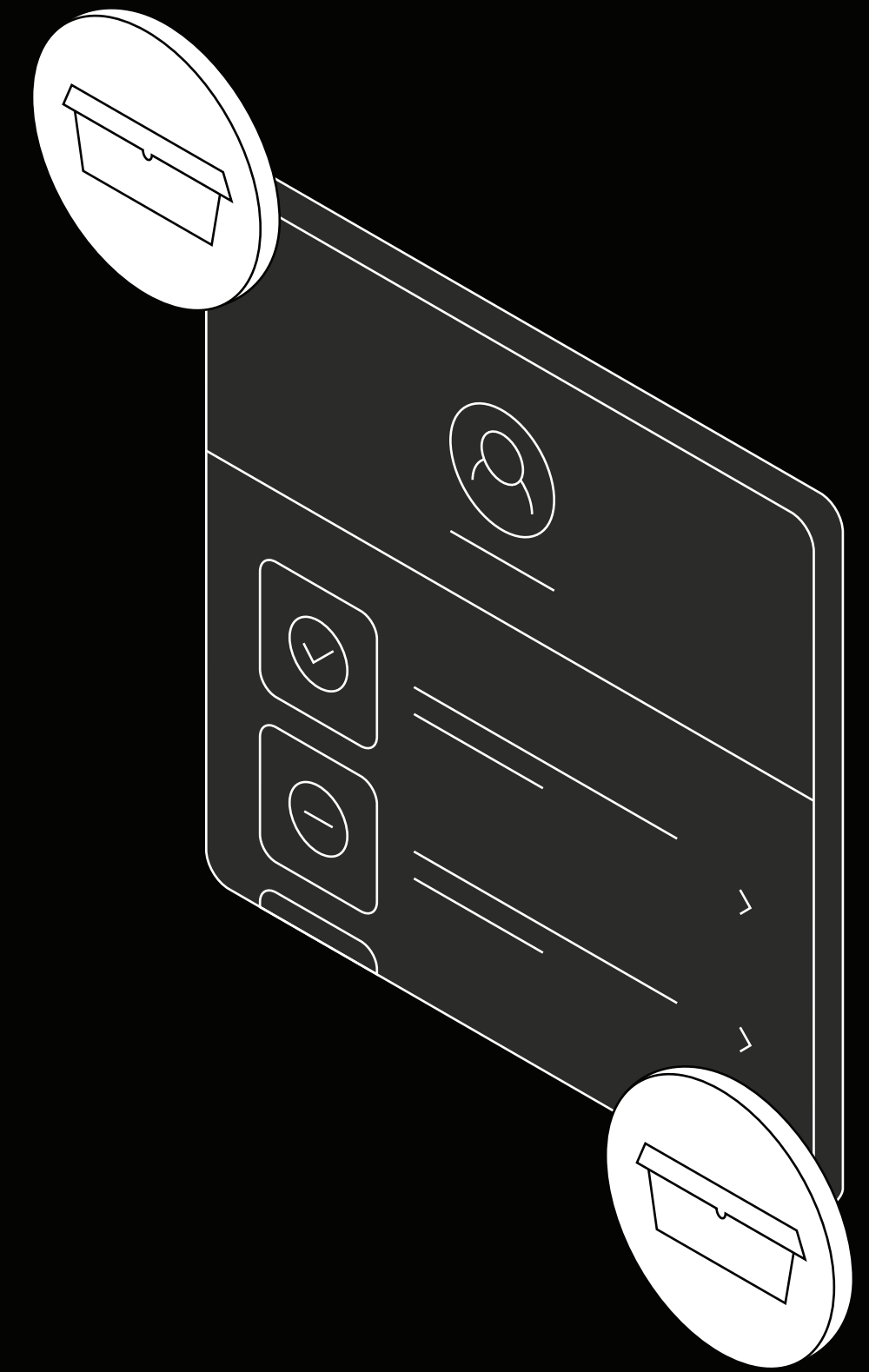

92% of restaurants plan to do community engagement.

41%
of restaurants added or improved customer loyalty and incentives.

42%
of restaurants added or expanded marketing efforts.

46%
of restaurants say that automating communication with customers would help fill critical gaps in staffing.

DID YOU KNOW?

[Square Customer Engagement](#) gives you access to diner profiles and insights. Restaurants can discount specific groups, offer loyalty rewards, and target customer segments for marketing campaigns based on previous transaction histories.

90% of restaurants say that the community stepped up to support them:

Q: In which of the following ways, if any, has your community provided support for your business?

Increased purchases from existing customers **58%**

Increased interest from new customers **56%**

Purchased gift cards **49%**

Donations or grants **36%**

“ Without the community? I can say that we wouldn't be standing here today. The community has supported us by coming in, showing us love, ordering from us, whether it be pickup, curbside, or on a different delivery platform. It brings you back to your roots. Even though Savannah has a lot of tourism, your roots are your customers, your everyday customers.”

Kenneth Brown
Co-owner, Sisters of the New South,
Savannah, GA



Tips

- Analyze your customer data to understand what appeals to them and how you can continue to delight them.
- The meaning of community has evolved not only to mean the regulars in your neighborhood, but people from all over who love your brand. Build connections on multiple platforms, including an email newsletter and consistent social media.
- Offer branded merch so customers can become ambassadors for your restaurant.
- Implement a diner engagement or [loyalty rewards program](#), which has become more common even for higher-end restaurants. Loyalty can be so much more than a punch card: You can personalize perks, give exclusive access to events, and target customers with discounts on new offerings.

FOR MORE INSIGHTS

BY INDUSTRY

Read the full reports for 2022

[The Future of Commerce](#)

[The Future of Retail](#)

[The Future of Beauty](#)



METHODOLOGICAL NOTES

The Square Consumer Survey was conducted by [Wakefield Research](#) among 1,000 nationally representative U.S. adults ages 18+, between October 6th and October 17th, 2021, using an email invitation and an online survey. The data was weighted to ensure reliable and accurate representation of the U.S. adult population, ages 18+.

The Square Retail Survey was conducted by Wakefield Research among 500 U.S. retail owners and managers, between October 6th and October 17th, 2021, using an email invitation and an online survey.

Results of any sample are subject to sampling variation. The magnitude of the variation is measurable and is affected by the number of interviews and the level of

the percentages expressing the results. For the interviews conducted in this particular study, the chances are 95 in 100 that a survey result does not vary, plus or minus, by more than 3.1 percentage points for the consumer audience, and 4.4 percentage points for the spa and salon owners/managers audiences, from the result that would be obtained if interviews had been conducted with all persons in the universe represented by the sample.

About Square

Where others see challenges, business owners see possibilities. Square builds tools that let businesses bring those possibilities to life by enabling them to reach customers online and in-person, manage their front- and back-of-house operations, and access financing. Square can help your business succeed — on your own terms.

[Learn more at Square.com.](#)